



replacement parts industries, inc.

CALL 800-221-9723 or 818-882-8611 • FAX 818-882-7028  
E-MAIL: techsupport@rpi.com • WEBSITE: www.rpiparts.com

"The Alternate Source™"

# PCK128 THERMOSTAT CONVERSION KIT INSTALLATION INSTRUCTIONS

(Replaces obsolete Hydraulic Thermostat, previously RPI Part #PCT006)

## PARTS CHECK LIST

- (1) Wire Harness
- (1) Solid State Controller (RPI Part #PCT169)
- (1) Potentiometer Controller Knob
- (1) Thermistor (RPI Part #PCT135)
- (1) Face Plate for mounting Potentiometer
- (1) Adhesive-backed Drilling Template for installing the Solid State Controller
- (1) Adhesive-backed Cut Out Template for Outer Casing
- (1) 16" Rubber "U" Channel for Casing Cut Out Area
- Package of hardware including:
  - (2) #6-32 x 1/2" Ig. Phillips Pan Head Screws
  - (2) No. 6 Lockwashers
  - (2) No. 6 Flat Washers
  - (2) #6-32 Hex Nuts
- Package of hardware including:
  - (2) #10-24 x 3/4" Ig. Phillips Pan Head Screws
  - (2) No. 10 Lockwashers
  - (2) No. 10 Flat Washers
  - (2) #10-24 Hex Nuts
- (4) 3/16" Female Crimp-on Connectors (To be used only if machine has lights with 3/16" connectors)
- Wiring Diagram decal

## REQUIRED TOOLS CHECK LIST

- Flat Head Screwdriver
- Phillips Head Screwdriver
- Duckbill Pliers
- 11/16" Open End Wrench
- 5/16" Wrench or Pliers
- Electric Drill
- 5/32" Drill Bit
- 3/16" Drill Bit
- Soldering Iron and Solder
- Tin Shears
- Razor Knife
- Crimping Tool
- Teflon® Tape or Pipe Sealant
- Diagonal Cutters
- 3/4" Socket with 1/2" Drive Ratchet

See inside for  
Installation Instructions

## WIRING HARNESS INSTALLATION INSTRUCTIONS

The harness should be positioned so that the connection to the solid state controller will not place any undo stress on the terminal connections.

All of the wiring harness terminations have been numbered, referring below to the **Wiring Diagram - Figure C**, all the termination points have numbers corresponding to the numbers on the harness wires.

The **Wiring Harness Chart - Figure D** shown below provides a step-by-step or wire by wire process in connecting the new harness to the machine.

The self-stick Wiring Diagram is enclosed and should be placed on to the reservoir for future reference.

**Note: There is a change to the wiring of the overheat thermostat. Make sure that you follow the wiring diagram, as the enclosed harness does not contain the wiring change on the heating element side of the firewall.**

The majority of the harness connections are via push-on terminals. There are three wires (#12, 13 and 14) that involve the power cable and have no terminals on them. They will be connected directly to their mating wires via wire nuts. **Note:** On some older machines, the Power and Heat lights used 3/16" slip-on connectors. The harness is supplied with 1/4" connectors. For the few machines that have the 3/16" connectors, (4) 3/16" female connectors are enclosed. Cut off the 1/4" connectors and crimp the 3/16" connectors in their place.

**FIGURE C  
WIRING DIAGRAM**

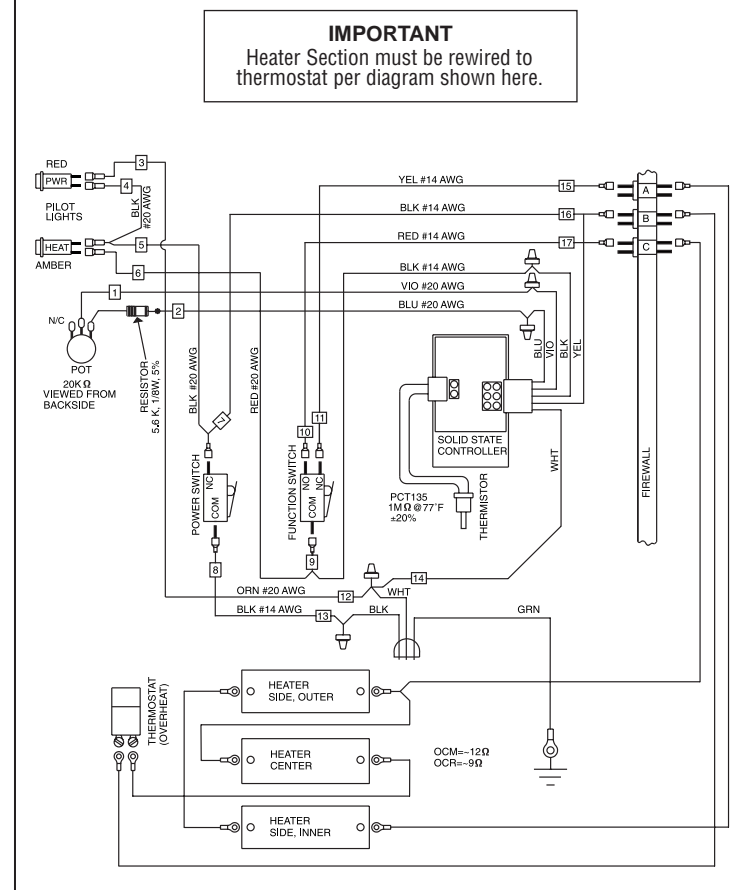

**FIGURE D  
WIRING HARNESS CHART**

TERMINAL #	WIRE COLOR	GAUGE	CONNECT TO
4	Black	20	One side of Heat light
5	Black	20	One side of Power light
3	Orange	20	Other side of Power light
6	Red	20	Other side of Heat light
17	Red	14	Function switch NO
10	Red	14	Firewall terminal C
15	Yellow	14	Function switch NC
11	Yellow	14	Firewall terminal A
9	Black / Red	14 & 20	Function switch COM
16	Yellow / Black	14 & 20	Firewall terminal B
7	Black / Black	14 & 20	Power switch NC
8	Black	14	Power switch COM
	Power connector Black	N/A	Splice with #13/8 (14 gauge Black wire)
	Power connector White	N/A	Splice with White #14 and Orange #12/3 White
	Power connector Green	N/A	Use a ring terminal fasten to main frame with at #6 nut and bolt

# INSTALLATION INSTRUCTIONS TO CONVERT OLDER OCM & OCR AUTOCLAVES FROM A HYDRAULIC THERMOSTAT CONTROL TO A SOLID STATE CONTROL.



*Please refer to the enclosed Parts Check List to verify that all necessary items are enclosed in this package. In addition, you may want to review the Required Tools Check List prior to installation.*

**NOTE**

*The dry heat function cannot be used after conversion.*

**WARNING: Before Starting Procedure, Unplug Autoclave from Power Source.**

- 1) Remove the outside cover of the autoclave.
- 2) If there is a circuit breaker mounted on the rear of the bottom plate, it should be removed and discarded.
- 3) Remove and discard the hydraulic thermostat.
 

**NOTE:** The removal of the thermostat can be simplified if the hydraulic line of the thermostat is cut as close as possible to the rear of the chamber with a pair of diagonal wire cutters. This will allow the use of a 3/4" socket wrench to remove the threaded fitting and attached thermostat from the rear of the chamber. This fitting is usually extremely tight and may require the use of a 1/2" drive with a long bar for additional leverage.
- 4) Remove and discard the interlock panel and the black button from the front of the machine.
- 5) Remove bottom plate of the autoclave to expose the heating elements and wiring. (There will be some rewiring later in the process.)
 

**NOTE:** In order to remove the bottom plate from the autoclave, it usually is necessary to remove the reservoir drain line. If the drain line fitting is located on the underside of the reservoir it will be necessary to remove the 5/16" line that runs from the main valve assembly to the rear of the chamber to allow access to the compression nut that is on the drain tube.
- 6) Remove the wiring from both lamps and all of the switches (Power On and Heat On) and the wiring up to the feed through connectors mounted on the firewall.
- 7) If the machine has two power switches, only one will be used. It does not matter which one is used, but **do not remove the unused switch.**

- 8) To install the temperature control potentiometer (RPI Part #PCC112) **READ THIS STEP THOROUGHLY BEFORE PROCEEDING.** Attach the circular faceplate to the machine. **Do not** remove the adhesive backing from the faceplate at this time. Align the center hole of the faceplate to the shaft hole. When aligning the faceplate to the front panel, take note of the positions of the present holes in the panel that were used to mount the interlock panel. Make sure that either of the two holes needed to mount the new faceplate to the panel are either fully aligned with the old holes in the panel or not aligned at all. When you mount the new faceplate to the panel, it will serve as a template for which to drill the new holes for mounting the faceplate.

**If there is partial alignment on the hole, the drill bit will wander into the soft aluminum faceplate instead of cutting into the hard steel front panel. This will damage the new faceplate.** Aligning an old hole with one of the new ones will slightly misalign the shaft hole which will be hidden by the potentiometer knob. After determining the best place to position the faceplate, remove the backing, press it into position and proceed to drill one or both of the mounting holes with a **5/32" drill**. Clean out all drill shavings. Mount the faceplate using the enclosed hardware: **(2) #6-32x1/2" lg. Phillips Pan Head Screws, (2) No. 6 lock washers, (2) No. 6 flat washers and (2) #6-32 hex nuts.**

- 9) Mount the potentiometer to the faceplate, with the terminals pointing up, using the star washer and hex nut that came with the potentiometer.

To install the knob on the potentiometer, turn the shaft to its fully clockwise position. Install the knob on the shaft with the pointer at **12 o'clock** and tighten the knob set screw with an Allen wrench. This is the setting you will use to calibrate the **270°F** point.

- 10) Install the thermistor assembly using Teflon® tape or pipe sealant in the same hole where you removed the bulkhead fitting from the old controller. (Be sure to clean the threads in the machine prior to installing the thermistor.)

- 11) Mounting the Solid State Controller. An adhesive-backed template has been supplied for placement and drilling convenience. See **Mounting the Solid State Controller - Figure A** for proper location. Use a **3/16" drill** for holes. For mounting the controller, the following enclosed hardware should be used: **(2) #10-24 x 3/4" lg. Phillips Pan Head screws, (2) No. 10 lockwashers, (2) No. 10 flat washers and #10-24 hex nuts.** In order for the outside casing to fit back onto the machine, a section of the casing must be cut away. An adhesive-backed template is supplied for this purpose. Refer

to **Mounting the Solid State Controller - Figure B** for proper location. After you cut and remove the cut out section, use the enclosed rubber "U" channel to line the sharp edges.

- 12) The thermistor and cable assembly can now be connected via the molex plugs to the solid state controller.
- 13) Install the new Wiring Harness. Refer to the **Wiring Harness Installation Instructions** on the back page before proceeding to Step #14.

- 14) Check all wiring and connections before applying power to the machine.
- 15) With the front temperature control (20K pot) set to the **12 o'clock** position (**270°F**), run the autoclave and adjust the trim pot on the solid state controller for proper operation at **270°F**.
- 16) Once satisfied with all test results, replace outside casing of the machine.

## MOUNTING THE SOLID STATE CONTROLLER

### FIGURE A TEMPLATE INSTRUCTIONS

- 1) Peel off backing to expose adhesive on template.
- 2) Using the left hand corner of the casing (viewed from the rear), match up the correct edge of the template (outside edge for OCM – inside edge for OCR) and press into place. Note direction of holes to be drilled. The right hand hole is above the left hand hole. Use a 3/16" Drill Bit to drill holes.

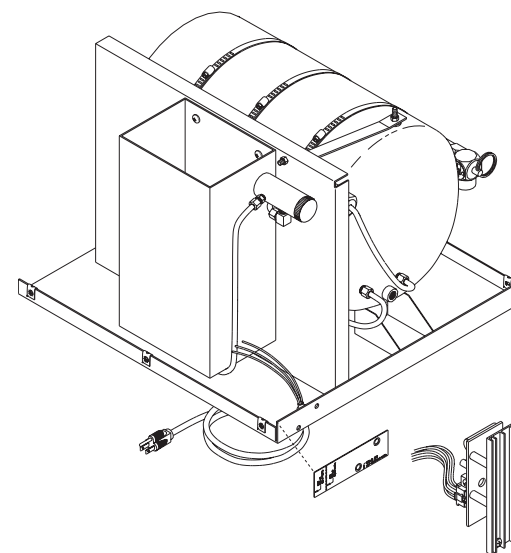

### FIGURE B TEMPLATE INSTRUCTIONS

- 1) Peel off backing to expose adhesive on template.
- 2) Using the rear left hand corner of the casing (viewed from the rear), match up the correct edge of the template (outside edge for OCM – inside edge for OCR) and press into place.
- 3) Using tin shears, cut along the dotted line and remove the excess material.
- 4) Line the sharp edges of the cut out area with the enclosed rubber "U" channel.

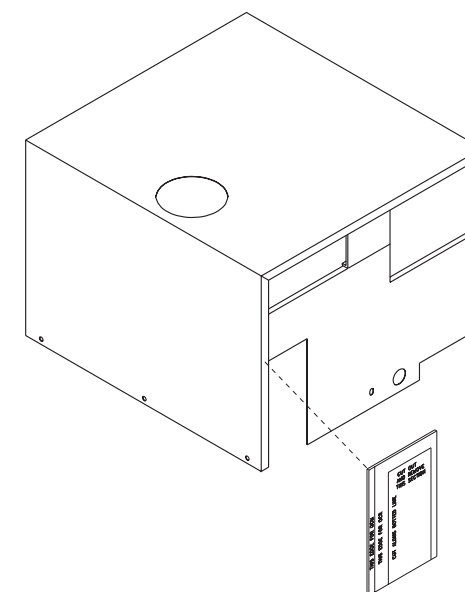



**replacement parts industries, inc.**

"The Alternate Source"®

CALL 800-221-9723 or 818-882-8611 • FAX 818-882-7028

E-MAIL: techsupport@rpiparts.com • WEBSITE: www.rpiparts.com

# PCK128

## THERMOSTAT CONVERSION KIT TEMPLATES

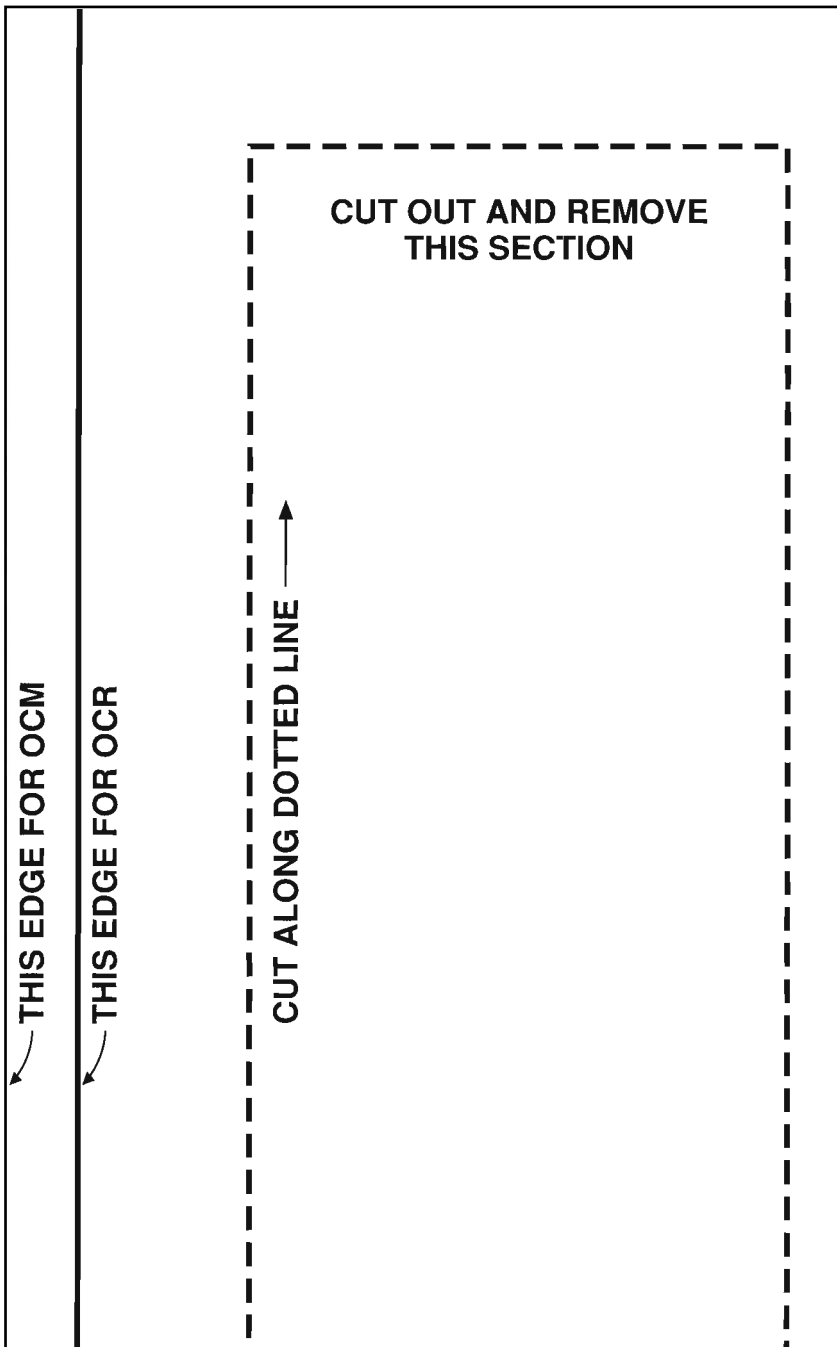

Adhesive-backed Cut Out Template for Outer Casing

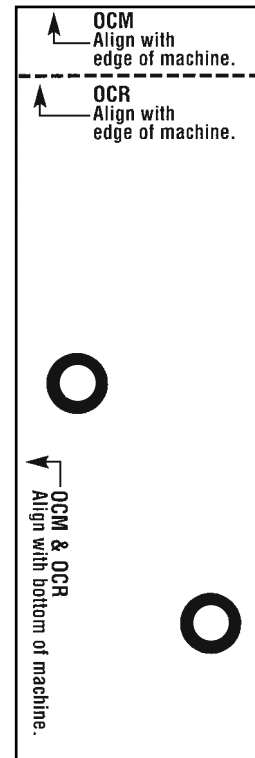

Adhesive-backed Drilling Template for installing the Solid State Controller